

Accessories

ACCESSORIES FOR ON/OFF VERSION



15AA1330
Steel cable suspension kit.
Cable length 3000mm.



15AA09
End cap.



15AA09ELDX
15AA09ELSX
Live end 250V-50Hz max 16A.



15AA05DX
15AA05SX
L coupler ON-OFF 250V-50Hz
max 16A.



15AA06DX
15AA06SX
T coupler ON-OFF 250V-50Hz
max 16A.



15AA07
X coupler ON-OFF 250V-50Hz max 16A.



15AA12
Flexible coupler ON-OFF 250V-50Hz max
16A.



15AA11
Concealed straight coupler
ON-OFF 250V-50Hz max 16A.

ACCESSORIES FOR DALI VERSIONS



15AA165P
15AA167P
5 pole / 7 pole-ceiling rose power cable.
Cable length 2000mm.



15AA13D
15AA13DH: for H version
Steel cable suspension kit.
Cable length 1500mm.



15AA1330D
15AA1330DH: for H version
Steel cable suspension kit.
Cable length 3000mm.



15AA14D
Ceiling mounting.



15AA17D
Bracket for recessed installation.



15AAGP1D
Additional IP40 cover strip.
Length 1000mm.



15AA09D
End cap.



15AA09DI
End cap for recessed version.



15AA09DH
End cap for H version.



15AA09ELDXD
15AA09ELSXD
Live end 250V-50Hz max 16A.



15AA09ELDXDI
15AA09ELSXDI
Live end 250V-50Hz max 16A
for recessed version.



15AA09ELDXDH
15AA09ELSXDH
Live end 250V-50Hz max 16A
for H version.

Technical Note

ACCESSORIES FOR DALI VERSIONS



15AA05DXD
15AA05SXD
L coupler 250V-50Hz max 16A for DALI version.



15AA05DXDI
15AA05SXDI
L coupler for recessed version.



15AA05DXDH
15AA05SXDH
L coupler 250V-50Hz max 16A for H version.



15AA06DXD
15AA06SXD
15AA08DXD
15AA08SXD
T coupler (internal 08/external 06) 250V-50Hz max 16A for DALI version.



15AA06DXDI
15AA06SXDI
15AA08DXDI
15AA08SXDI
T coupler (internal 08/external 06) for recessed version.



15AA06DXDH
15AA06SXDH
15AA08DXDH
15AA08SXDH
T coupler 250V-50Hz max 16A for H version.



15AA07D
X coupler 250V-50Hz max 16A for DALI version.



15AA07DI
X coupler for recessed version.



15AA07DH
X coupler 250V-50Hz max 16A for H version.



15AA11D
Concealed straight coupler 250V-50Hz max 16A.



15AA12D
Flexible coupler 250V-50Hz max 16A.



15AATC
Cutting tool for track conductors.

WEIGHT AND ELECTRICAL DIAGRAMS

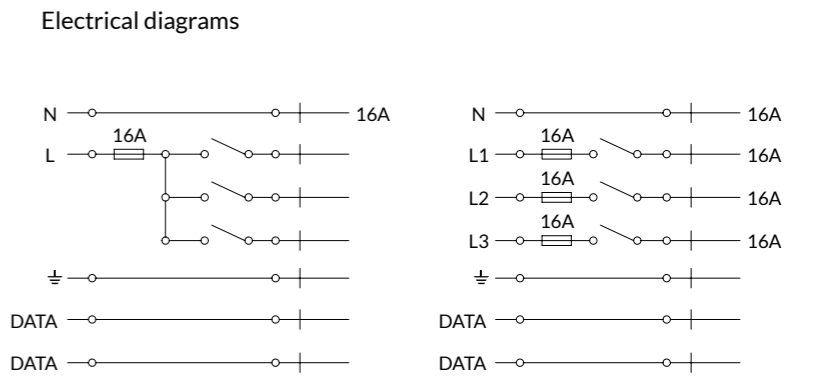
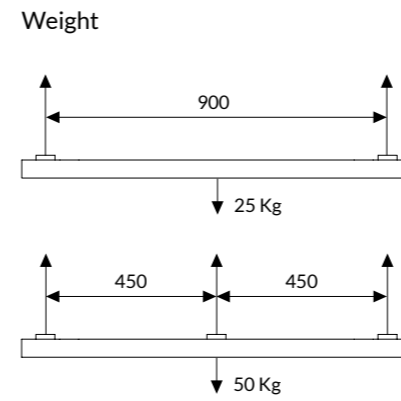

EXAMPLE OF INSTALLATION DIAGRAM WITH ITEM CODES

